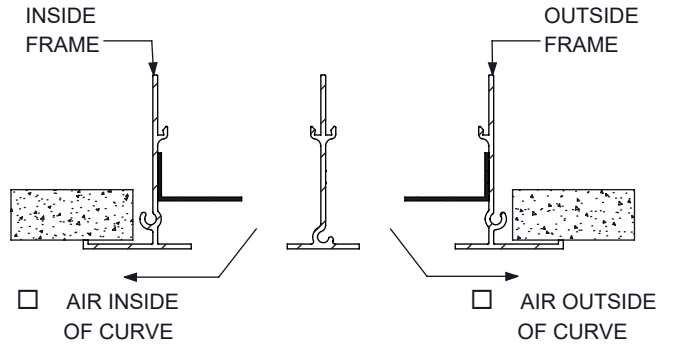
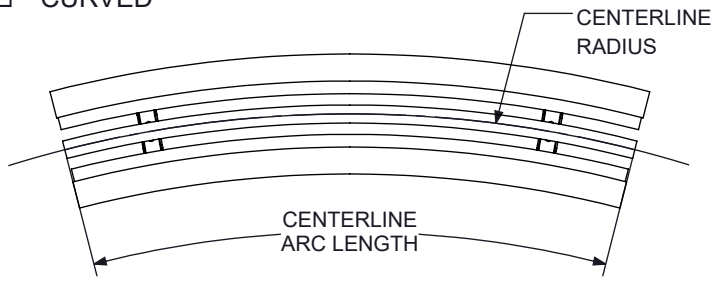
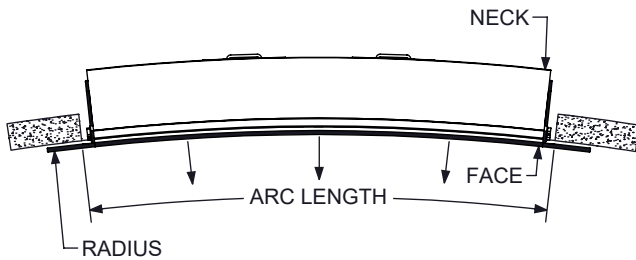
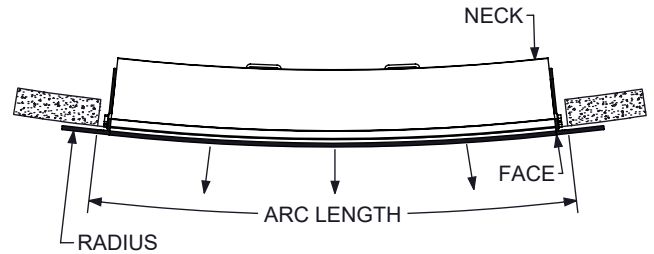

CURVED 1900
 ALUMINUM LINEAR SLOT DIFFUSER

SUBMITTAL SHEET
CURVED STYLE:
 CURVED

 CONCAVE

 CONVEX

FRAME STYLE :

- A
- B
- C
- D
- E
- F
- I
- J
- M

SLOTS :

- 1 SLOT
- 2 SLOT
- 3 SLOT
- 4 SLOT
- 5 SLOT
- 6 SLOT
- 7 SLOT
- 8 SLOT

SLOT WIDTHS :

- 50 - 1/2"
- 75 - 3/4"
- 10 - 1"
- 15 - 1.5"
- 20 - 2"

END BORDER :

- BUTT CUT
- END PLATE / BUTT CUT
- END PLATES
- BUTT CUT / END PLATE
- END CAP / BUTT CUT
- END CAPS
- BUTT CUT / END CAP

PATTERN CONTROLLERS :

- 0 - NO BLADES
- F - BLADES

FINISH :

- 44 - BRITISH WHITE
- 01 - MILL
- 35 - BLACK
- 07 - ENAMEL PAINT MATCH
- 10 - ALUMICAN
- 49 - OFF WHITE
- 81 - CLEAR ANODIZE
- 84 - LIGHT BRONZE ANODIZE
- 85 - MEDIUM BRONZE ANODIZE
- 86 - DARK BRONZE ANODIZE

ARC LENGTH : _____

RADIUS : _____

NOTES :

- CONSTRUCTION IS EXTRUDED ALUMINUM
- CURVED LENGTHS GREATER THAN 72" [1829] ARE FURNISHED IN MULTIPLE SECTIONS
- ADJUSTABLE BLADES, 24" [610] LONG, CHANGE AIR FLOW DIRECTION AND VOLUME
- MINIMUM ARC LENGTH IS 12"
- USE CURVING REQUEST EXCEL SHEET LINK FOR CALCULATOR AND ORDERING
- BLADE FINISH WILL MATCH SELECTED FINISH

 KRUEGER
 CURVING
 REQUEST
 FORM

DIMENSION ARE GIVEN AS INCHES [MM]

Revision Date: 5/15/2024

Form: DS0717

Replaces: NEW SUBMITTAL

Product Information is Subject to Change Without Notice